



**DO NOT** cut BFM™ Spigot and re-size before installation.



Size fitting to pipe. Pipe circumference may need to be expanded or reduced to suit the BFM™ Spigot.



Avoid (if possible) cutting the tail down. If it is necessary to shorten the tail, do not cut the tail down any more than 25mm. Welding, any closer than 25mm to the formed end, could result in welding shrinkage effecting the tolerance of fit between the flexible connector cuff into the BFM™ fitting.



Tack BFM™ Spigot to correct sized pipe.



Peen the tacked joint to ensure correct fit.



Weld fitting on. Dress and polish to required standards.

*All care must be taken to ensure that the circumference of the formed end after fitting and welding, remains the same size as supplied, to ensure fitting tolerance of the connector.*



# Installation & Welding Guidelines

## BFM™ Fitting

- Note: 1. The stainless steel spigots (flanges) have a tail 52mm (2") long. These can be easily cut down or cut on an angle to suit your existing pipe work, see installation instructions for more information.
2. It is important to weld the spigots onto your pipe work with the length of the flexible connector in mind. Standard length flexible connectors will be stocked and hence will be more readily available, and less expensive than non standard lengths.
3. For applications where there is a possibility for static build up, e.g. wood dust, flour, milk powder etc., we recommend using a static dissipative wire (strip), connecting the two BFM™ Spigots together.

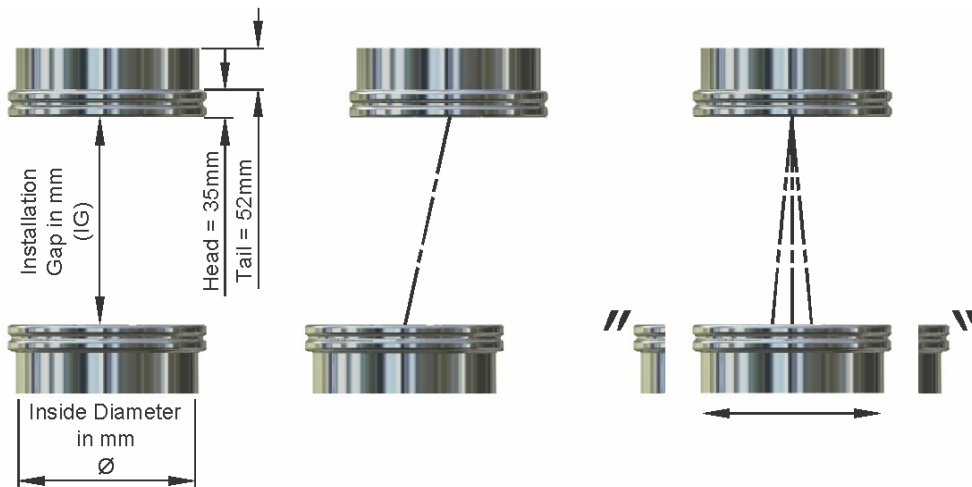

In-line static  
equipment  
IG = CL — 10mm  
(Minimum)

Off Set  
equipment  
IG = CL —  
20mm  
(Minimum)

Oscillating  
equipment  
IG = CL — 40mm  
(Minimum)

CL = Connector Length (See BFM® Flexible Connector Sheet)

*BFM Global makes no warranty of any kind, expressed or implied, except that goods sold shall be of merchantable quality, free of manufacturing defect, and the buyer assumes all risk and liability resulting from the use of the goods, whether used singly or in combination with other products.*